

[®] **MECCO**
MACHINES

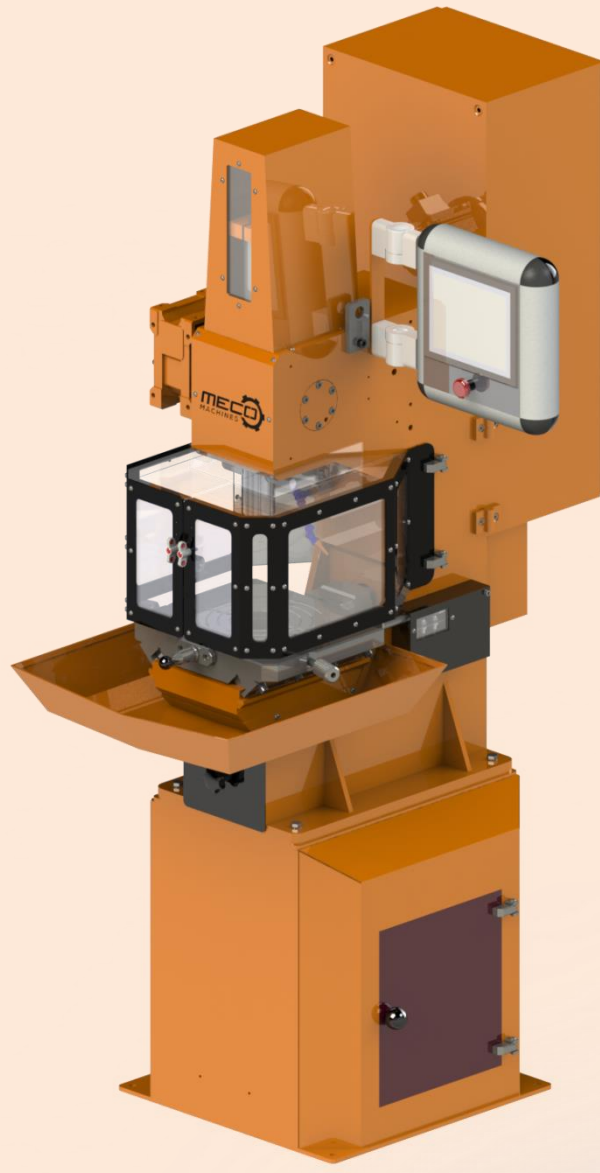

Technical Features
MEC-55x275x400CNC





MEC-55x275x400CNC

Technical features

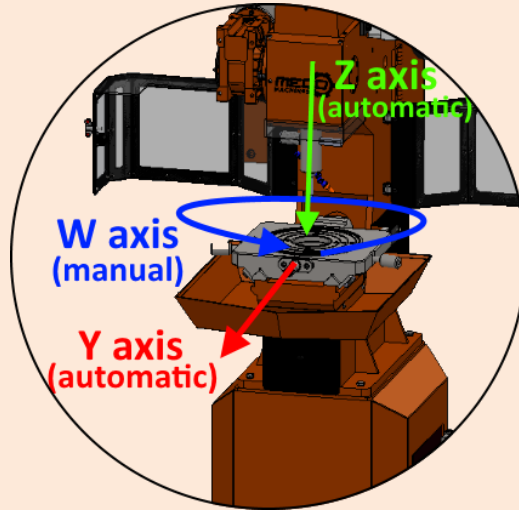

- ✓ **2 AUTOMATIC AXES AND 1 MANUAL.** Thanks to the electronic control systems of last generation that have been incorporated in this model for two of its three axes, has achieved greater precision and a higher degree of automation. The machine can work in automatic mode, so that the operator can simply handle replace the part once the machine has finished the process of pre-programmed machining. Undoubtedly, the MECO Keyseaters are designed to increase the production capacity of our customers.

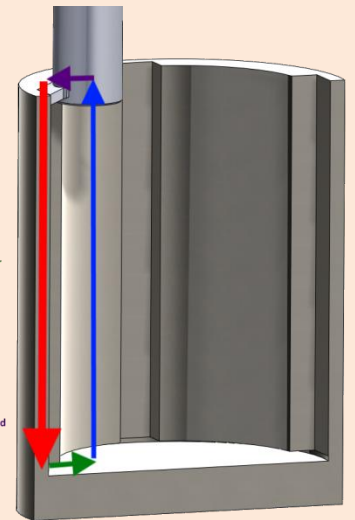

- 1) Downward stroke:** Cutting is produced during the downward stroke
- 2) Cutter separation:** When the tool finishes the downward stroke, the workpiece is separated from the tool in order to liberate the tool during the upward stroke
- 3) Upward stroke:** The cutter rise again without any contact with the piece until keep located over the piece.
- 4) Approaching:** The workpiece moves until the cutter penetrates the programmed cutting depth

- ✓ **BLADE SEPARATION DURING THE RISE.** All Mecco broaching have an automatic system that is responsible for separating the blade from the workpiece during the ascent phase. This system has managed to substantially extend the life of the tool.

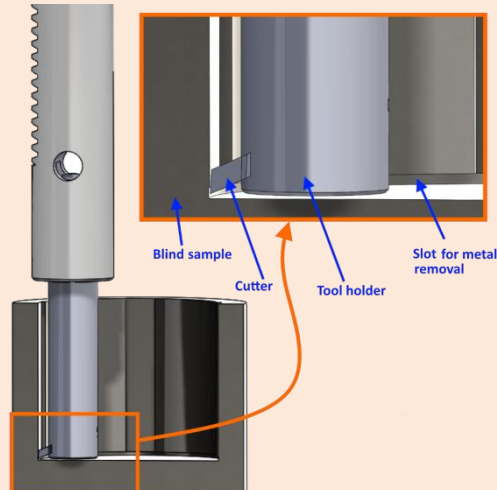

- ✓ **BLIND SAMPLES.** Properly regulating the limit switches can enter the tool in blind parts and machining grooves or keyways.

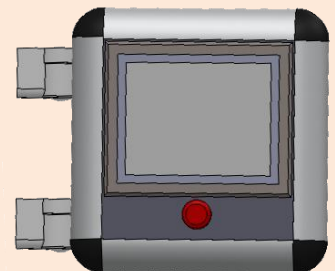

- ✓ **COMMUNICATION WITH THE USER.** The user accesses the machine control via a touch screen. The software has been developed and simplified to facilitate the user to control the process. It is not a complex CNC system but is a very intuitive and easy to use software and requires no prior training and any operator can control the process.

EXPERIENCE AND KNOW-HOW

We have more than 30 years of experience in the field of manufacturing and developing industrial machinery

INTERNATIONAL PRESTIGE

We have a large international presence with customers in more than 15 countries around the world.



I+D

Innovation and development are one of the main assets that we have in MECO to remain at the forefront of a highly competitive and changing as the sector of the machine tool environment.



MECO-55x275x400CNC

Technical data

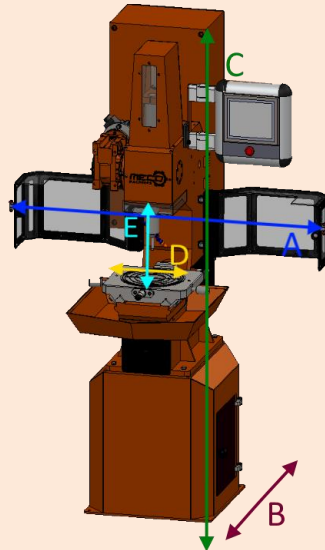

Machine Dimensions

- **A** (Maximum Width with doors open): 1265mm
- **B** (Maximum Depth of the machine): 1100 mm
- **C** (Maximum Higher of the machine): 1800 mm
- **D** (Maximum diameter of the sample): 400 mm
- **E** (Total working area): 275 mm
- (Machine weight): 640 kg

Electrical parameters

- Apparent power: 5677 VA
- Voltage: 400V
- Frequency: 50Hz.
- Connection: III+N+T

Specifications of the Z Axis (automatic)

- Maximum Speed Z Axis: 9 m/min
- Total Stroke Z Axis: 262 mm
- Total Engine Power Z axis: 0,75 kW
- Maximum working force 7kN
- Reduction ratio: 20:1

Specifications of the Y Axis (automatic)

- Maximum Speed Y Axis: 1,8 m/min
- Stroke in the Y Axis in +: 36 mm
- Stroke in the Y Axis in -: 20 mm
- Total Engine Power Z axis: 400W
- Maximum working force: 45kN
- Reduction ratio: 10:1

Specifications of the W Axis (manual)

- Total degrees rotation w: 360°
- Dimensions of rotary plate: Ø 240 mm
- It has a calibrated nonius and brake for blocked the plate to the desired degree.
- Preset divisions for 2, 3, 4, 5, 6, 7, 8, 10, 12, 14, 16 slots.

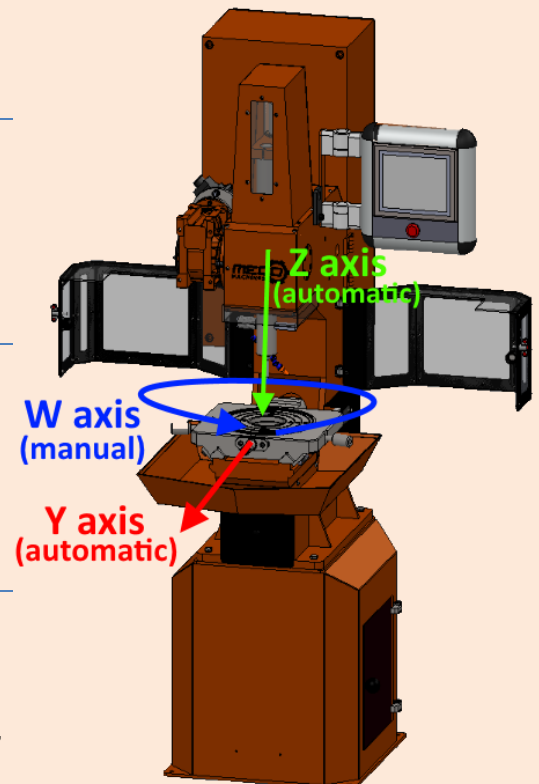

HUMAN TEAM

The multidisciplinary team consists of qualified and committed professionals. It is certainly a fundamental and indispensable pillar on which our projects are held.

START UP

In MECO we like to make life easier for our customers from the start. So we take care of the installation and commissioning of the machine at the site assigned by the client.

TRAINING IN THE CUSTOMER HOME

In addition to the launch of the machine, each customer receives a training day with which it is intended that the user is familiar with the operation of newly acquired equipment.

WARRANTY

The factory warranty is 1 year for any manufacturing fault or defect to CE standard.



MECO-55x275x400CNC

Versatility and manufacturing capacity

Versatility is undoubtedly the main differentiating factor of MECO broaching regarding our competence as a single machine meets the same production capacity hitherto achieved with two machines, Keyseaters and broaching.

Our broaching machine offer all the features and specifications of the most sophisticated slotting machine of the market. To all this we add the ability to perform internal spline, which until now could only be done with broaching, just without having to spend a fortune on brushes. While brush costs several thousand Euros, the cost of a tool for MECO Keyseater is negligible. But this is not the only competitive advantage over broaching, so are the functional solutions that MECO Slotting offer and you can perform with precision, inner grooved on both straight and tapered blind parts, something impossible for broaching.

Below are some of the pieces that can be done with our broaching.

CUSTOMER CARE

In MECO we have a customer service department that is in charge of solving a professional and friendly manner any needs that may arise to our customers.

CUSTOMIZED SOLUTIONS

Experience tells us that every customer is different and not all have the same needs. So from MECO we add value to our product as customized solutions.

TECHNICAL ASSISTANCE

If anything the MECO broaching is characterized by high reliability and robustness. However, our technical department is fully segmented and organized to solve in the shortest time, technical contingency that may arise anywhere in the world.

✓ STRAIGHT SLOTS

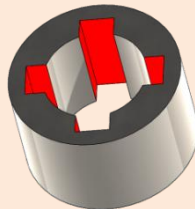

✓ CONICAL KEYWAYS

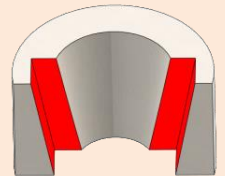

✓ EXTERNAL SLOTS

(ONLY IN 70&80 PREMIUM AND CNC MODELS)

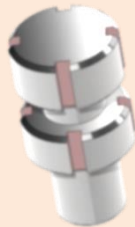

✓ KEYWAYS IN BLIND SAMPLES.



✓ SPECIAL KEYWAYS



✓ SQUARES



✓ HEXAGONAL

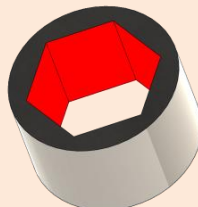

✓ SPECIAL SAMPLES

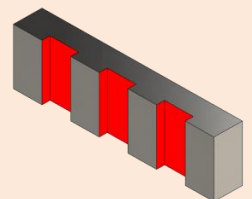

✗ EXTERNAL SPLINES

(ONLY IN PREMIUM MODELS)

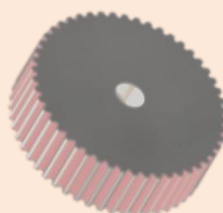

✗ INTERNAL SPLINES AND IN BLIND HOLES

(ONLY IN PREMIUM MODELS)





MEC-55x275x400CNC

Equipment, tools and customized solutions

CUTTERS IN STOCK

In MECO always we have a large stock of cutters and standard tools. The cutters will be delivered within 24h in tolerances H7 and P9 for Spain and south Europe. Other tolerances or special cutters 5-6 days. Other destinations on request.

SPECIAL CUTTERS

From the technical office of MECO we will bring solutions and special customized cutters. We are in charge of manufacturing the cutters with the desired customer profile and the required tolerances. We also conduct studies and tests with different materials to optimize and maximize the life of the tool in special applications.

SUPPLIES

In MECO we guarantee our customers the supply of spare parts for the entire life cycle of the machine.

In MECO we are also manufacturers of accessories, tools and tool and spare parts for all our machines. Our delivery times are very small and offer technical and maintenance service anywhere in the world. In addition to a great product, our experience and know-how enables us to offer customized solutions according to the specific needs of each client.

✓ TOOLHOLDERS

They are easily interchangeable thanks to a design with clamping system "Morse taper" and extraction wedge.

PN TYPE

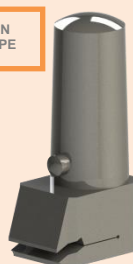

SV TYPE



Special cutters. We handle manufacture special cutters with the desired customer profile and the required tolerances. We also perform tests on pieces of customers to determine the optimum blade material and maximize the life cycle of the same.

✓ CUTTERS

Our low-cost blades are the only consumable required by MECO Keyseater Machine. They are designed to maximize battery life.

PN TYPE



SV TYPE

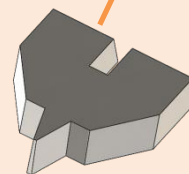
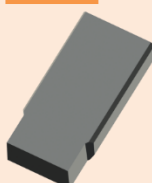

Geometric limits cutters and tool holder standard

	WIDTH AND KIND OF TOOL (mm)	TOOL HOLDER REQUIRED	A (mm)	B (mm)	C (mm)	D (mm)
MEC-55 CNC SV	3 FLG SV	3mm SV	30	68	2,0	10
	4 FLG SV	4mm SV	35	70	2,5	13
	5 FLG SV	5mm SV	50	71	3,0	14
	6 FLG SV	6mm SV	60	77	4,6	20
	8 FLG SV	8mm SV	90	80	4,6	24
	10 FLG SV	10mm SV	120	86	4,6	31
	12 FLG SV	12mm SV	125	89	4,5	35
	14 FLG SV	14mm SV	125	90	5,3	36
	16 FLR SV	16mm SV	123	93	6,9	38
MEC-55 CNC PN	18 FLR SV	18mm SV	125	93	6,9	40
	18 FLR PN	From 18mm to 28mm PN	200	116	8,8	66
	20 FLR PN		200	116	8,8	66
	22 FLR PN	From 28mm to 40mm PN	200	116	9,8	67
	25 FLG PN		200	116	9,8	67
	28 FLG PN		200	116	11,8	68
	32 FLG PN		200	116	12,8	69
	36 FLG PN	From 40mm to 50mm PN	200	116	13,8	70
	40 FLG PN		200	116	15,8	71
	45 FLG PN	From 40mm to 50mm PN	200	116	19,8	73
50 FLG PN	200		116	23,8	75	

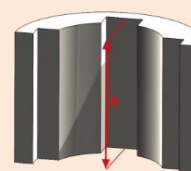

A: Maximum Higher of the Keyway.

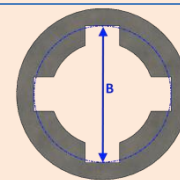

B: Reach maximum diameter of the cutter with the sample centered.

C: Maximum Depth of the slot.

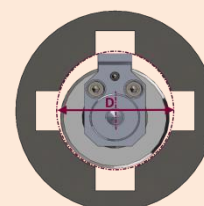
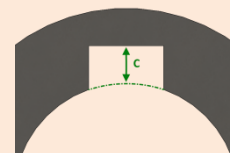

D: Minimum diameter of the hole.

*Meco reserves the right to modify the parameters of the preceding table without notice.

*The upper limitations correspond to standard toolholders and cutters. However, Meco can develop specials toolholders and cutters following the customers need.